

IGU SLIM



The In Ground Unit (IGU) provides round-the-clock power for days, weeks or even months on end. It minimises the potential for damage owing to vandalism and harsh weather because it operates unattended with the lid locked down, with only the power cable protruding.

IN GROUND UNIT SIZES AND DIMENSIONS

Name	Overall Size (mm)	Depth (mm)	Lid In-tray depth (mm)	Income Supply
Slim	570x386	250	67	Single Phase Only

For requirements outside of our standard design parameters please contact us for further assistance, either by **telephone 020 8227 0208** or email **info@popuppower.co.uk**

ELECTRICAL CONFIGURATIONS

- Quick secure around the clock access for days, weeks or even months on end
- Single phase option only with combination of 16 amp and 32 amp sockets, maximum of 2 sockets
- Recessed lid to accept paving or any other infill to blend in with surrounding area
- Suitable for use in areas with light vehicle traffic, tested to EN124 B125 load classification
- Security locking head and yellow safety tread plate as standard
- Manufactured to ISO 9001 quality management system
- Manufactured from BS EN 10025 S275 JR high grade structural steel plate to ensure longevity and stability under load
- Compliant with all accessibility regulations
- Galvanised to BS EN ISO 1461 to guarantee 55 micron minimum average zinc coating
- Bespoke versions available upon request

GALVANISING STANDARDS

We guarantee a minimum galvanised coating of 55 microns as standard. For further information on the corrosion rate in your area please visit: www.galvanizing.org.uk/check-your-corrosion

Galvanised Longevity Table

Corrosion Rate Key (See above website to find your local area)	1	2	3	4	5
Average Corrosion Rate (Microns (µm)/year)	0.5	1	1.5	2	2.5
55 Microns (µm) minimum average coating (Standard) (years)	110	55	36	27	22
85 Microns (µm) minimum average coating (Chilled Iron Shot Blasting SA 2.5) (years) (Available at request)	170	85	56	42	34
Average Corrosion Rate Combined with effect of de-icing salts (Microns (µm)/year)	2.5	3	3.5	4	4.5
55 Microns (µm) minimum average coating (Standard) (years) (Exposed to de-icing salts)	22	18	15	13	12
85 Microns (µm) minimum average coating (Chilled Iron Shot Blasting SA 2.5) (years) (Exposed to de-icing salts) (Available at request)	34	28	24	21	19

ACCESSORIES

Pop Up Power® Locking Key (pictured right) - one key supplied with each unit



TECHNICAL DRAWING (EXAMPLES)

Unit top aspect

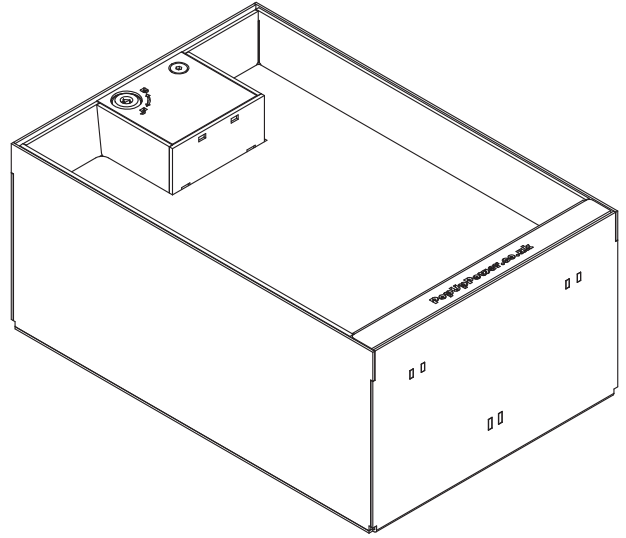
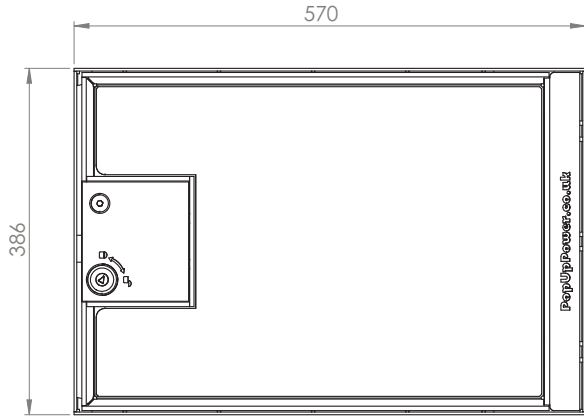

Unit side/end aspect

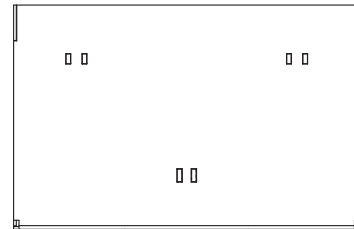
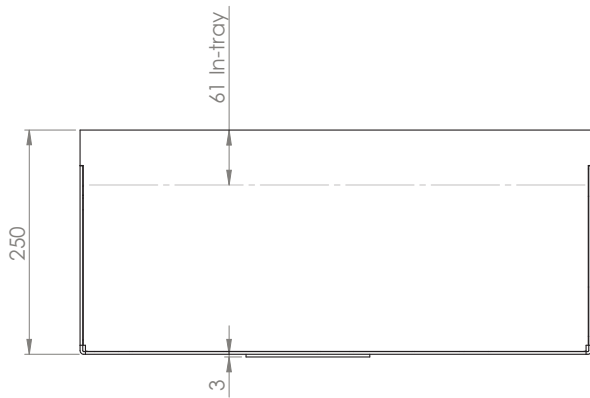

SLIM IGU IN-SITU

Unit open



Unit closed

